

# CURVETTE

## R/RSC-Series

### SINGLE POLE ROCKER & PADDLE SWITCHES

Since its introduction, the Curvette switch has become the barometer for versatility and performance in the switch market. Self cleaning contacts, international approvals, along with a wide variety of circuits, ratings, and actuator options make the Curvette the switch of choice for many markets.



#### Product Highlights:

- ♦ Two color visi rocker to indicate “on” function
- ♦ Ratings to 20A
- ♦ Oval or rectangular bezels
- ♦ Patented mounting wings accommodate a wide range of panel openings

#### Typical Applications:

- ♦ Appliance
- ♦ HVAC
- ♦ Food Service
- ♦ Transportation



### Dielectric Strength

UL/CSA:  
1000V - live to dead metal parts  
VDE:  
4000V - live to dead metal parts;  
750V - across open contacts

### Mechanical Life

100,000 cycles

### Operating Temperature

32°F to 185°F (0°C to 85°C)

### Electrical Life

100,000 cycles

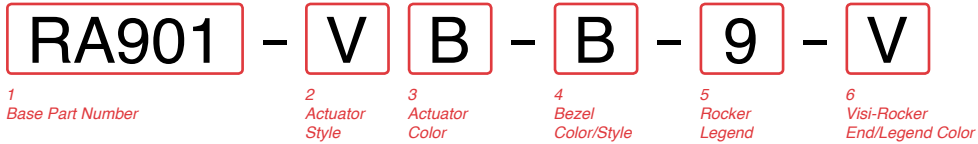

**1 BASE PART NUMBER: SERIES / CIRCUITRY / RATING <sup>1</sup> / TERMINATION**  
**10A 250 VAC; 16A 125 VAC; 3/4 HP 125-250 VAC; 10(4) A 250 VACu T85**

	Solder Lugs	.250 Tabs	Wire Leads
OFF-NONE-ON	<b>RA900</b>	<b>RA901</b>	<b>RA905</b>
ON-NONE-ON	<b>RB900</b>	<b>RB901</b>	<b>RB905</b>
ON-OFF-ON <sup>3</sup>	<b>RC910</b>	<b>RC911</b>	<b>RC915</b>
OFF-NONE-(ON) <sup>2</sup>	<b>RD220</b>	<b>RD221</b>	<b>RD225</b>

**15A 250 VAC; 20A 125 VAC; 3/4 HP 125-250 VAC**

	Solder Lugs	.250 Tabs
OFF-NONE-ON	<b>RSCA200</b>	<b>RSCA201</b>
ON-NONE-ON	<b>RSCB200</b>	<b>RSCB201</b>

**4 BEZEL COLOR / STYLE**

STANDARD	OVAL
<b>B</b> Black (matte)	<b>1</b> Black (gloss)
<b>W</b> White (matte)	<b>2</b> White (gloss)

**5 ROCKER LEGEND**

	molded in	hot stamp
NO LEGEND	<b>0</b>	<b>0</b>
Off-On vertical	<b>1</b>	<b>A</b>
Off-On horizontal	<b>2</b>	<b>B</b>
O-I horizontal	<b>8</b>	<b>D</b>
O-I vertical	<b>9</b>	<b>E</b>
dual OFF-ON/O-I	n/a	<b>H</b>

**2 ACTUATOR STYLE**

<b>M</b> Momentary Rocker	<b>R</b> Rocker
<b>P</b> Paddle	<b>V</b> Visi-rocker (2 color)

**3 ACTUATOR COLOR**

<b>1</b> Black (gloss)	<b>B</b> Black (matte)
<b>2</b> White (gloss)	<b>W</b> White (matte)

**6 VISI-ROCKER END / LEGEND COLOR**

<b>N</b> N/A
<b>B</b> Black
<b>V</b> Visi-red
<b>W</b> White

Notes:  
 PC Terminals also available, consult factory for details.  
 1 For additional ratings, consult factory.  
 2 Rating is 8A 250 VAC, 12A 125 VAC, 1/2 HP 125-250 VAC, and must specify M actuator style.  
 3 Not rated at 3/4 HP 125-250 VAC  
 ( ) indicates momentary function.

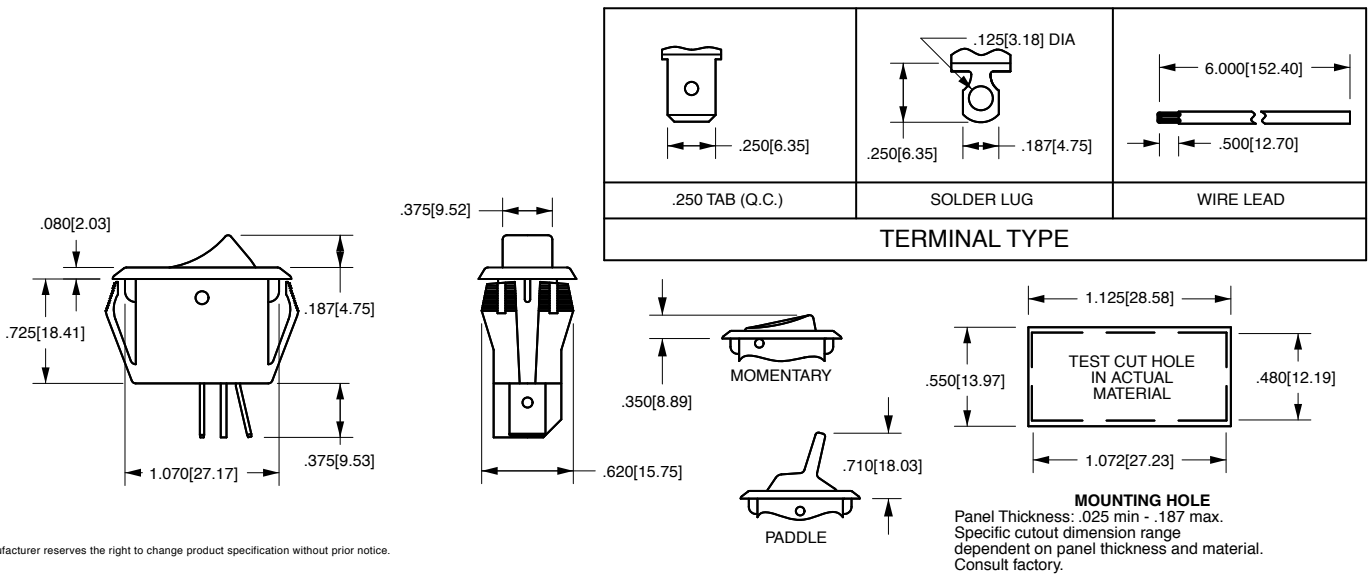

\*Manufacturer reserves the right to change product specification without prior notice.